

GAIN AND OFFSET ADJUSTMENTS SEALED (CODE 'Y')

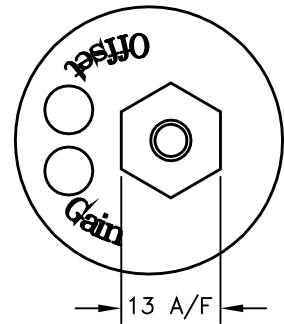

IP67 SHORT CABLE GLAND - AXIAL (CODE 'Mxx')

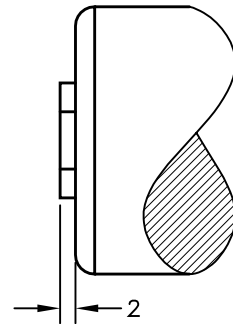

ELECTRICAL OPTIONS/ SPECIFICATIONS

| OUTPUT OPTION | OUTPUT | SUPPLY | |
|---------------|--------------------------------------|--------|----------|
| A | 0.5 TO 4.5V RATIO METRIC | 5V | STANDARD |
| B | ±5V | ±15V | |
| C | 0.5 TO 9.5V | 24V | BUFFERED |
| D | ±10V | ±15V | |
| E | 0.5 TO 4.5V | 24V | |
| F | SUPPLY CURRENT 12mA TYP. 20mA MAX. | 24V | |
| G | 4 TO 20mA 2-WIRE | 24V | |
| H | 4 TO 20mA 3-WIRE SINK | 24V | |
| | 4 TO 20mA 3-WIRE SOURCE | 24V | |
| | SINK VERSION OUTPUT COMPLIANCE 5-28V | | |
| | SOURCE VERSION DRIVE 300Ω MAX TO 0V | | |

CABLE: 0.2mm², O/A SCREEN, PUR JACKET - SUPPLIED WITH 50cm OR REQUIRED LENGTH IN cm. e.g. 'L50'

3-CORE: JACKET Ø4mm

4-CORE: JACKET Ø4.6mm

CABLE/CONNECTOR* CONNECTIONS;

3 CORE 4 CORE CONNECTOR

| | | | |
|--------|--------|----|---------------------------|
| RED | RED | :1 | +Ve |
| BLACK | GREEN | :3 | 0V |
| WHITE | YELLOW | :4 | -Ve - OPTIONS: B OR D |
| SCREEN | BLUE | :2 | OUTPUT |
| SCREEN | SCREEN | :4 | BODY - OPTIONS: A, C, E-H |

*CONNECTORS; MAXIMUM CONDUCTOR CROSS SECTION 0.75mm²
RANGE OF DISPLACEMENT FROM 0-5° TO 0-15° e.g.12°, IN INCREMENTS OF 1°.

BODY MATERIAL:- STAINLESS STEEL.

FLANGE BASE MATERIAL:- ALUMINIUM.

SERVO MOUNT MATERIAL:- ALUMINIUM.

FURTHER OPTIONS:

SPRING RETURN (CODE 'N') AVAILABLE UP TO ±50°

CALIBRATED OUTPUT, PHYSICAL STOPS ±55°

NOTE STANDARD DEVICE HAS NO STOPS.

| | | |
|---|------------------------------------|-----|
| D | ELEC. OPTIONS AMENDED. | PDM |
| E | FLANGE TH'KNNESS ADDED. | PDM |
| F | ADDITIONAL DIMS/VIEWS ADDED. | PDM |
| G | DISP. 5 TO 15° WAS 5 TO 20° RAN442 | PDM |
| H | RANGE NOTE AMENDED - RAN1200 | PDM |



DRAWINGS NOT TO BE CHANGED WITHOUT REFERENCE TO THE CHANGE PROCEDURE.
CHANGES TO PARTS USED IN INTRINSICALLY SAFE PRODUCT MUST BE APPROVED BY THE AUTHORISED PERSON
THIS IS AN UNCONTROLLED PRINT AND WILL NOT BE UPDATED.

POSITEK
P
LIMITED

| | | | | | |
|---|----------|-------------------------------------|----------------|---------|--------------|
| D | 18/10/06 | | CHECKED BY | X | ±0.4 |
| E | 05/01/10 | | RDS | X.X | ±0.2 |
| F | 06/07/11 | | | X.XX | ±0.1 |
| | | | | | DIMS mm |
| G | 07/11/13 | DESCRIPTION | | | |
| H | 11/09/17 | P502 RIPS SMALL ANGLE ROTARY SENSOR | | | |
| | | SCALE | DRAWING NUMBER | P502-11 | REV H |
| | | 10mm | | | SHEET 1 OF 1 |



P502 SMALL ANGLE ROTARY SENSOR

High-resolution angle feedback for industrial and scientific applications

- **Non-contacting inductive technology to eliminate wear**
- **Angle set to customer's requirement**
- **Compact, durable and reliable**
- **High accuracy and stability**
- **Sealing to IP65/IP67 as required**



As a leading designer and manufacturer of linear, rotary, tilt and intrinsically safe position sensors, Positek® has the expertise to supply a sensor to suit a wide variety of applications.

Our P502 is an affordable, durable, high-accuracy rotary sensor designed for industrial and scientific feedback applications, like the P500 but with better resolution at smaller angles of deflection.

The P502, like all Positek® sensors, provides a linear output proportional with angle of rotation. Each unit is supplied with the output calibrated to the angle required by the customer, between 5 and 15 degrees and with full EMC protection built in. The sensor provides a linear output proportional with input shaft rotation, which has full 360 degree rotational freedom. There is a machined registration mark to identify the calibrated mid point.

It is particularly suitable for OEMs seeking good sensor performance for arduous applications such as industrial machinery where cost is important. Overall performance, repeatability and stability are outstanding over a wide temperature range.

The P502 has long service life and environmental resistance with a rugged stainless steel body and shaft, the flange and servo mounts are anodised aluminium. The flange or servo mounting options make the sensor easy to install, it also offers a range of mechanical and electrical options. Environmental sealing is to IP65 or IP67 depending on selected cable or connector options.

SPECIFICATION

Dimensions

| | |
|----------------------------|--------------------------------|
| Body diameter | 35 mm |
| Body Length (to seal face) | 44 mm standard, 50 mm buffered |
| Shaft | 15 mm Ø 6 mm |

For full mechanical details see drawing P502-11

Independent Linearity

$\leq \pm 0.25\%$ FSO @ 20°C

Temperature Coefficients

$< \pm 0.01\%$ /°C Gain &

$< \pm 0.01\%$ FS/°C Offset

> 10 kHz (-3dB)

> 300 Hz (-3dB) 2 wire 4 to 20 mA

Frequency response

Resolution

Infinite

Noise

$< 0.02\%$ FSO

Torque

< 20 mNm Static

Environmental Temperature Limits

Operating

-40°C to +125°C standard

-20°C to +85°C buffered

-40°C to +125°C

Storage

IP65/IP67 depending on connector / cable option

Sealing

EN 61000-6-2, EN 61000-6-3

EMC Performance

Vibration

IEC 68-2-6: 10 g

Shock

IEC 68-2-29: 40 g

MTBF

350,000 hrs 40°C Gf

Drawing List

P502-11

Sensor Outline

3D models, step or .igs format, available on request.

Do you need a position sensor made to order to suit a particular installation requirement or specification? We'll be happy to modify any of our designs to suit your needs - please contact us with your requirements.

For further information please contact:

www.positek.com sales@positek.com

Tel: +44(0)1242 820027 fax: +44(0)1242 820615

Positek, Andoversford Industrial Estate, Cheltenham GL54 4LB. U.K.

P502-17t

1 of 2



P502 SMALL ANGLE ROTARY SENSOR

High-resolution angle feedback for industrial and scientific applications

How Positek's technology eliminates wear for longer life

Positek's Inductive technology is a major advance in displacement sensor design. Our displacement transducers have the simplicity of a potentiometer with the life of an LVDT/RVDT. Our technology combines the best in fundamental inductive principles with advanced micro-electronic integrated circuit technology. A Positek sensor, based on simple inductive coils using Positek's ASIC control technology, directly measures absolute position giving a DC analogue output signal. Because there is no contact between moving electrical components, reliability is high and wear is eliminated for an exceptionally long life. It also overcomes the drawbacks of LVDT technology – bulky coils, poor length-to-stroke ratio and the need for special magnetic materials, no requirement for separate signal conditioning. We also offer a range of ATEX-qualified intrinsically-safe sensors.

| | | | | | | | |
|------|--------------|--------|-------------|-------------|--------|--------|--------|
| P502 | a | b | c | d | e | f | g |
| | Displacement | Output | Adjustments | Connections | Option | Option | Z-code |

| a Displacement | Value |
|---|--------------------------------------|
| Factory set to any angle from 0-5° (±2.5°) to 0-15° (±7.5°) (e.g. 0-8°) | 8 |
| b Output | Code |
| Supply V_{dc} (tolerance) | Output |
| +5V (4.5 - 5.5V) | 0.5 - 4.5V (ratiometric with supply) |
| ±15V nom. (±9 - 28V) | ±5V |
| +24V nom. (13 - 28V) | 0.5 - 9.5V |
| ±15V nom. (±13.5 - 28V) | ±10V |
| +24V nom. (18 - 28V) | 4 - 20mA 2 wire |
| +24V nom. (13 - 28V) | 4 - 20mA 3 wire Sink |
| +24V nom. (9 - 28V) | 0.5 - 4.5V |
| +24V nom. (13 - 28V) | 4 - 20mA 3 wire Source |
| Supply Current: 'A' 10mA nominal, 12mA max. 'B', 'D' & 'G' 12mA nominal, 15mA max. 'E' 26mA max. 'F' & 'H' 32mA nominal, 35mA max. | |
| c Calibration Adjustments | Code |
| Accessible default | blank |
| Sealed | Y |
| d Connections | Code |
| Connector IP65 4 pin (3+earth) DIN 43650 'C' | J |
| Connector IP65 4 pin (3+earth) DIN 43650 'C' pre-wired | Jxx |
| Cable gland IP67 M12, nylon | Lxx |
| Cable gland, short† IP67, metal | Mxx |
| Specify required cable length 'xx' in cm. e.g. L2000 specifies axial cable gland with 20 m of cable, 50 cm supplied as standard. †Nb: restricted cable pull strength. | |

| e Shaft Option | Code |
|--|-------------|
| None default | blank |
| Sprung to stop up to 100° maximum | N |
| f Sensor Mounting | Code |
| Flange default | blank |
| Servo Mount | P |
| See drawing P502-11 for details. | |
| g Z-code (optional) | Code |
| Connector IP67 M12 IEC 61076-2-101 must have options 'Y' & 'J' | Z600 |
| Connector IP67 M12 IEC 61076-2-101 must have option 'J' | Z601 |

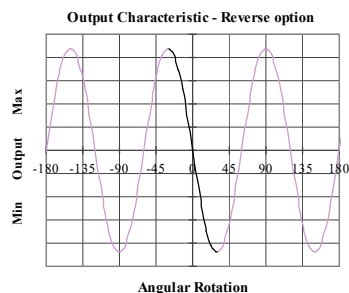
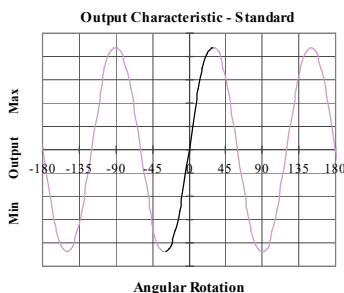

For further information please contact:

www.positek.com sales@positek.com

Tel: +44(0)1242 820027 fax: +44(0)1242 820615
Positek, Andoversford Industrial Estate, Cheltenham GL54 4LB. U.K.



Installation Information

P502 SMALL ANGLE ROTARY SENSOR

| Output Option | Output Description: | Supply Voltage: V_s (tolerance) | Load resistance: (include leads for 4 to 20mA O/Ps) |
|---------------|--------------------------------------|--------------------------------------|--|
| A | 0.5 - 4.5V (ratiometric with supply) | +5V (4.5 - 5.5V) | $\geq 5k\Omega$ |
| B | $\pm 5V$ | $\pm 15V$ nom. ($\pm 9 - 28V$) | $\geq 5k\Omega$ |
| C | 0.5 - 9.5V | +24V nom. (13 - 28V) | $\geq 5k\Omega$ |
| D | $\pm 10V$ | $\pm 15V$ nom. ($\pm 13.5 - 28V$) | $\geq 5k\Omega$ |
| E | 4 - 20mA 2 wire Current Loop | +24V nom. (18 - 28V) | $\approx 0 - 300\Omega$ max. @24V ~ 1.2 to 6V across 300 Ω $\{R_L \text{ max.} = (V_s - 18) / 20^{-3}\}$ |
| F | 4 - 20mA 3 wire Sink | +24V nom. (13 - 28V) | $\approx 0 - 950\Omega$ max. @24V ~ 3.8 to 19V across 950 Ω $\{R_L \text{ max.} = (V_s - 5) / 20^{-3}\}$ |
| G | 0.5 - 4.5V | +24V nom. (9 - 28V) | $\geq 5k\Omega$ |
| H | 4 - 20mA 3 wire Source | +24V nom. (13 - 28V) | $\approx 0 - 300\Omega$ max. ~ 1.2 to 6V across 300 Ω |

Not all output options available - see product datasheet for full options list

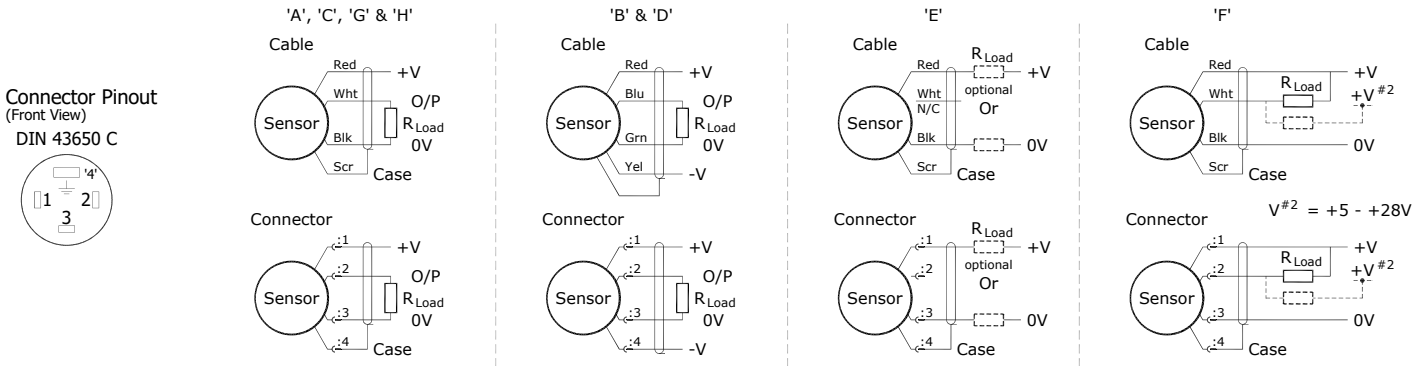

Gain and Offset Adjustment: (Where accessible - Typically $\pm 10\%$ Min available)

To adjust the gain or offset use a small potentiometer adjuster or screwdriver 2mm across. Do not apply too much force on the potentiometers

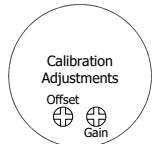

Mechanical Mounting: Flange mounted or servo mount, with appropriate clips - see drawing P502-11. The sensor should be mounted with minimal axial and radial loading on the shaft for optimum life. It is recommended that the shaft is coupled to the drive using a flexible coupling. Tests indicate that life in excess of 16 million cycles can be achieved with 1kg side and end load.

Output Characteristic: The sensor has full rotational freedom and six sectors, 60° apart, over which linear response can be achieved. At the mid point of the calibrated range the output signal will be half full scale deflection, and the flat on the shaft is aligned with the registration mark in the base of the sensor. In the calibrated range the output increases as the shaft is rotated in an anti-clockwise direction viewed from the shaft. The calibrated output is factory set to be between 5 and 15°.

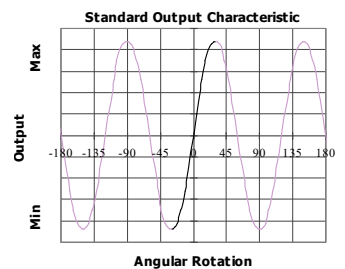

Incorrect Connection Protection levels:-

- A **Not protected** – the sensor is **not** protected against either reverse polarity or over-voltage. The risk of damage should be minimal where the supply current is limited to less than 50mA.
- B & D Supply leads diode protected. Output must not be taken outside $\pm 12V$.
- C & G Supply leads diode protected. Output must not be taken outside 0 to 12V.
- E, F & H Protected against any misconnection within the rated voltage.

For further information please contact:

www.positek.com sales@positek.com

Tel: +44(0)1242 820027 fax: +44(0)1242 820615

Positek, Andoversford Industrial Estate, Cheltenham GL54 4LB. U.K.